



## Agronomy Facts 69

# Manure Sampling for Nutrient Management Planning

## INTRODUCTION

Manure is an excellent source of many essential plant nutrients and, with proper management, can meet nearly all crop nutrient needs. Sampling manure for analysis is an essential and valuable nutrient management tool for determining the nutrients available in manure. Manure test results, combined with soil test recommendations and manure spreader calibration, form the basis for determining appropriate manure application rates to meet crop nutrient needs.

It is important to know the nutrient content of the manure being applied in order to maximize the economic benefit of the nutrients in achieving yields and reducing fertilizer costs. Likewise, knowing the nutrient content of manure is helpful in reducing the environmental impacts from excess nutrient application.

The purpose of this fact sheet is to highlight the importance and value of manure sampling and analysis and to outline practical guidelines and procedures for taking manure samples.

## WHY TEST MANURE?

Unlike fertilizer, manure form and composition, and therefore nutrient analysis, can vary widely. Manure nutrient content is obtained in two common ways for planning purposes: (1) manure sampling and laboratory analysis of manure produced on the farm, or (2) "book values." Book values are developed by averaging the results of a large number of tests for a common manure type (Figure 1).

Book values can be used as a starting point for estimating initial manure application rates when test results are not yet available. However, book values or averages seldom reflect the actual nutrient content of the manure from a specific farm. Variations in manure composition and nutrient content occur from farm to farm due to differences in diet and feeding programs, type and amount of bedding, the amount of rain or wash water added, manure handling, and manure storage. Proper sampling and analysis is the only way to obtain farm-specific manure nutrient content and avoid the adverse impacts of over- or underapplication of manure nutrients.

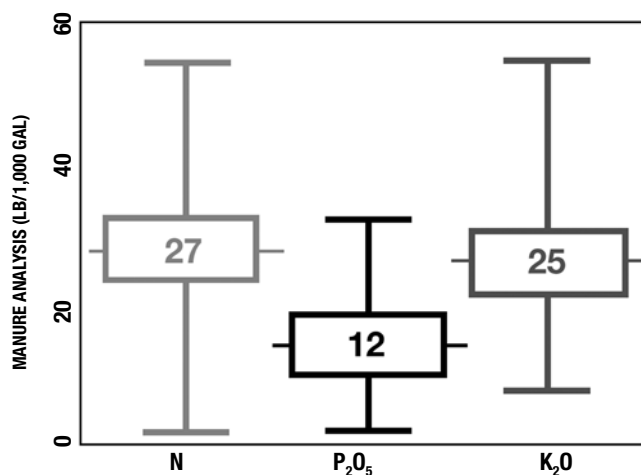

**Figure 1. Manure analysis average nutrient concentration and variations from 311 farmer-submitted dairy manure samples in Pennsylvania. Average values and the range of values for liquid dairy manure samples submitted to Penn State Agricultural Analytical Services over a period of time. The averages in the boxes are very close to most published book values for dairy manure, but the range in individual analyses is very wide. Summaries from many other labs have shown similar results.**

Source: Penn State Agricultural Analytical Service Laboratory.

## WHEN TO SAMPLE

Collecting a representative sample for analysis is the single most important factor affecting the accuracy of manure nutrient content. Obtaining a representative sample is also the most challenging aspect of the manure sampling process. Keep in mind that the sample must represent the actual manure being spread. If sampling is not done correctly, the results of the analysis can be worse than having no analysis at all.

Because only a small amount of manure is sent to the laboratory for analysis, it is imperative that the sample represent the average composition of the manure being applied. The two critical aspects of sampling are the timing of sampling with respect to the manure's application and the ease or difficulty of the required sampling procedure. Both of these factors are related to variations in nutrient content that occur over time or are present in manure based on how the manure is stored and handled.

Even on a single farm, both weather and management can affect the nutrient composition of manure. Seasonal variations in temperature and precipitation can change nutrient content through dilution, evaporation, and volatilization, particularly in uncovered storages and stacks. Manure stored in barns as bedded pack or litter or stored in covered stacks is typically not affected by weather, but there is often significant variation in nutrient content throughout the manure based on the uneven mixing of bedding, hay, and/or spilled feed. Finally, a single liquid manure source can have a large variation in nutrient content if the manure is not thoroughly agitated and mixed before spreading.

When is the ideal time to collect a manure sample?

Because the goal is to collect a sample that represents the manure actually being applied, the best time to sample is during loading or field application. The sample can be obtained during loading of manure application equipment or in the field as the manure is being spread. Sampling at this time has several advantages:

- The time-related changes in nutrient content caused by management and weather are minimized.
- The nonuniformity due to lack of mixing is reduced. Subsamples can be taken as the manure is loaded, which results in more representative samples.
- The difficulty of collecting representative samples while manure is in the storage, barn, or stack is reduced.
- The complexity of the sampling equipment required is reduced.
- In some cases, the sampling procedure is safer, reducing the risk of falling in or being overcome by gases.

There is one disadvantage to sampling during spreading: the analysis results from samples collected at this time will not be available to calculate manure application rates for that application. However, the results can be used to calculate future application rates. It is recommended that the manure nutrient content values used in calculating manure application rates be based on running averages or baseline values. To obtain these values, each manure group should be sampled annually for three to five years. After the initial period, manure can be sampled periodically to monitor the nutrient values. See the “Manure Analysis Records and Creating a Baseline” section for practical guidelines on how to use multiple manure analysis results. If there are changes in feeding programs or manure storage and handling, the manure should be resampled. As long as no significant changes are made in the production system, the nutrient content of the manure should remain fairly constant.

Some states may have specific regulatory requirements related to manure sampling that may vary from the general guidance provided above and elsewhere in this fact sheet. When developing a manure sampling program, farmers, consultants, and nutrient management planners should learn and integrate their state regulatory requirements with the guidance outlined in this fact sheet.

## **GENERAL MANURE SAMPLING GUIDELINES**

After selecting the manure testing lab, check with the lab for specific guidelines or requirements regarding sample size, package and shipping requirements and guidelines, analytical options, costs, and turnaround times. Some labs provide containers, labels, and submission forms. See the “Selecting a Lab” section for some practical considerations for choosing a manure analysis laboratory.

Generally, most sampling methods create a composite sample from multiple subsamples that have been thoroughly mixed. The necessary equipment and supplies will vary depending on the type of manure being sampled and the method of sampling.

Manure samples should be taken with clean steel or plastic shovels, scoops, or cups and placed in a clean five-gallon plastic bucket to make a composite sample. Using tools and equipment made of nonreactive materials, such as stainless steel and plastic, and thoroughly cleaning them between samples will prevent contamination of samples. Do not use galvanized containers because they can influence analysis results.

Composite samples should be sent to the lab in plastic bottles (liquid and solids), or one-gallon heavy-duty ziplock plastic bags can be used for dry material like broiler litter. Do not use glass containers for either sampling or shipping because of the risk of breakage, leakage, and possible injury.

Depending on the sampling method, other equipment such as tarps, a piece of plywood, or a solid manure sampling probe may be required. Ice chests should be used in warm weather to keep samples cool during the sampling process.

Each sample should represent the manure that is being land applied. In many liquid manure storage systems there is considerable variation in the manure, even within a storage unit. If liquid manure is agitated sufficiently to achieve uniformity throughout the storage, one sample is adequate to determine the nutrient levels of that manure. Note, however, that it is very difficult to uniformly mix large liquid storages (more than 250,000 gallons). If there are obvious changes in the manure as the storage is being emptied, such as consistency or color, several separate samples should be collected to represent this variation.

Sampling procedures vary depending on whether the manure is a solid or a liquid. Also, for each manure type there are several possible ways to collect a representative sample. These recommended sampling procedures are discussed below.

## **SOLID MANURE SAMPLING PROCEDURES**

The following sampling procedures can be used for manure, poultry litter, and compost. It is recommended that solid manure be sampled while loading the spreader or during application in the field. Sampling directly from a bedded pack or stockpile is not recommended. Samples should be collected throughout the entire emptying or application process. Samples should be taken from loads representing the beginning, middle, and end of the process.

### Sampling During Loading

During the process of loading the spreader take a sample of the manure and place it in the bucket. A minimum of five samples of approximately the same size should be taken while emptying the storage. Avoid atypical material such as large chunks of bedding. After all the samples have been collected in the bucket, the manure should be placed on a tarp, piece of plywood, or clean concrete surface and mixed thoroughly. Take a subsample from the mixed composite sample and fill the lab manure sample container.

### Sampling During Spreading

Spread a tarp or sheet of heavy plastic in the field and spread manure over this with the manure spreader. Collect the manure from the tarp or plastic sheet and place it in the bucket. Repeat this procedure with a minimum of five spreader loads throughout the emptying of the storage. After all the samples have been collected in the bucket, the manure should be placed on a tarp, piece of plywood, or clean concrete surface and mixed thoroughly. Take a subsample from the mixed composite sample and fill the lab manure sample container. This procedure is usually only practical for more solid manures.

### Sampling Daily Haul

Place a five-gallon bucket under the barn cleaner four or five times while loading the spreader. After all the samples have been collected in the bucket, the manure should be placed on a tarp, piece of plywood, or clean concrete surface and mixed thoroughly. If the manure is too wet to mix on a tarp, plywood, or concrete surface, mix the manure thoroughly in the bucket. Take a subsample from the mixed composite sample and fill the lab manure sample container. Repeat this several times throughout the year to determine variability over time.

### Sampling Stockpiles

Sampling directly from manure, compost, or litter stockpiles as described here is not recommended because it is difficult to obtain a representative sample. Testing during loading or application as explained above is the preferred method. One sample may be adequate for smaller, more homogeneous piles or compost that has been "turned." Multiple samples should be taken from larger piles to represent the variability of the material in the piles. In uncovered piles, avoid taking samples from the weathered exterior of the pile. Volatilization can affect the surface levels of nitrogen and rainfall can leach water-soluble nutrients into the pile. Take ten to twenty samples from widely dispersed areas of the entire pile. Samples should be collected from at least 18 inches below the surface of the pile. A large diameter auger bit and portable drill or soil sampler can be used to access manure deep within pile. After all the samples have been collected in the bucket, the manure should be placed on a tarp, piece of plywood, or clean concrete surface and mixed thoroughly. Take a subsample from the mixed composite sample and fill the lab manure sample container.

### In-house Sampling Poultry Litter

The consistency and nutrient content of dry litter will vary across the poultry house. Material under and near waterers and feeders will be different from the rest of the house. Manure from the brood and grow-out areas represent different manure groups and should be sampled separately. Use a solid manure sampling probe to collect fifteen to twenty samples from throughout the house to the depth of the litter to be removed. Collect samples from around waterers and feeders proportional to the space they occupy in the house. After all the samples have been collected in the bucket, the manure should be placed on a tarp, piece of plywood, or clean concrete surface and mixed thoroughly. Take a subsample from the mixed composite sample and fill the lab manure sample container. A sample taken while loading the spreader or during spreading will be a more representative sample than the method described here.

### LIQUID MANURE SAMPLING PROCEDURES

In most liquid manure storages there is some stratification of solids and, as a result, nutrients. Therefore, storage agitation is critical to obtain a homogeneous manure mix. This is important for both obtaining a representative sample and spreading a uniform manure. Agitating for two to four hours is the minimum; however, depending on the type of storage, a much longer agitation time may be required. If manure is not properly agitated, nitrogen and potassium will typically concentrate in top liquid portion, while phosphorus will be more concentrated in the solids accumulated on the bottom. Length of agitation time for sampling should be similar to agitation time done before the storage is emptied. For this reason, the most practical time to sample is when the storage is being emptied for field application. If the storage is not adequately agitated, there will likely be manure consistency and nutrient stratification. Figure 2 illustrates how manure analysis can vary within a storage without adequate agitation. In this example, manure in the last fifteen loads spread from this storage has two to three times more phosphorus than in the first forty-five loads spread. If the storage is known to be stratified, separate

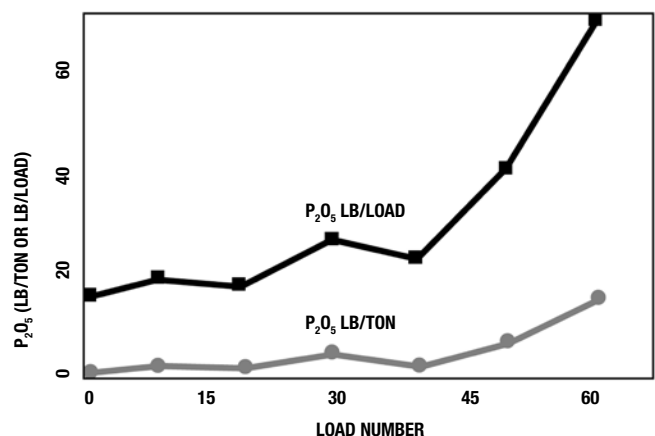

Figure 2. Variation in manure phosphorus analysis as a liquid swine manure storage is emptied.

Source: Les Lanyon, Penn State.

samples should be taken as the manure consistency or color changes during emptying.

The following sampling procedures can be used for liquid manure. The recommended procedures for liquid manure are to sample while loading the spreader or during application in the field.

### **Sampling During Loading**

Agitate the storage thoroughly before sampling. Collect at least five samples during the process of emptying the storage and loading the spreader. Save these samples in a bucket. When all of the samples have been collected, thoroughly mix the samples and take a subsample from this to fill the lab manure test container. Using a plunger with an up-and-down motion works well for mixing the manure in the bucket. If samples are collected over a period of several hours, store the bucket with manure samples on ice to prevent ammonia losses.

### **Sampling During Spreading**

This method can be used for spreader-applied manure, but it is strongly recommended for irrigated manure. Place buckets around the field to catch manure from the spreader or irrigation equipment. Place these to collect manure from more than one spreader load. Combine and mix the manure collected from different locations, and take a subsample from this to fill the lab manure test container. This method may give you “crop available ammonia nitrogen” as any ammonia losses may have already occurred prior to reaching bucket. What reaches the bucket is likely to soak into the soil and be available to the crop. If samples are collected over a period of several hours, store the bucket with manure samples on ice to prevent ammonia losses.

### **Sampling Directly from Storage**

Sampling a storage directly is much more difficult and likely to result in more variable results than sampling as the manure is loaded into the spreader. Agitate the storage thoroughly before sampling. Use a small bucket or tube to collect at least five samples from different locations in the storage. Combine these samples in a bucket, thoroughly mix the samples, and take a subsample from this to fill the lab manure test container. If samples are collected over a period of several hours, store the bucket with manure samples on ice to prevent ammonia losses.

## **SELECTING A LAB**

When selecting a manure analysis laboratory, it is best to ask some questions to ensure that you receive the information that you want at a competitive cost. This also allows the lab to best meet your needs. Following are six areas to explore with a manure analysis lab:

1. How many years has the laboratory been performing manure analysis? Labs should have at least two years of experience in manure testing.
2. Is the lab certified by an independent quality-control organization? The answer to this question should be “yes.” This ensures that the lab adheres to industry-sanctioned quality-control standards, which can help validate the results.

3. What manure analyses are included in the laboratory’s standard package?
4. How does the laboratory report its manure analysis results?
5. How are samples handled when they are received at the lab? The samples should be tested immediately. If that’s not possible, the samples should be refrigerated or treated to maintain their integrity until analyzed.
6. How long does a customer typically wait for results? Results should be compiled and delivered within a consistent and predictable amount of time.

One option, if testing manure for the first time, is to send exactly the same samples to at least three different labs so you can compare results. If results are similar, choose the lab that gives you the most value and service for your dollar. Remember, cheapest isn’t always best. Customer service is the hallmark of a reliable lab, so make sure you consider how well the lab lived up to its promises.

## **HANDLING AND SHIPPING SAMPLES**

Carefully follow all instructions from your manure testing lab for handling and delivering the samples to the lab. Proper care and handling of the sample will ensure that the samples sent for analysis are representative of the original manure nutrient content. Proper steps should be taken to avoid leakage, nutrient transformations such as volatilization, and moisture loss.

Liquid manure sample containers should never be filled more than three-quarters full. If using plastic bags, fill approximately one-half full, squeeze out the air, close, and seal. Samples should be double-bagged to prevent leaking.

Samples should be kept cool until they are sent to the lab. Most labs recommend freezing samples or keeping them on ice. Do not allow the samples to sit longer than one hour in a warm environment. Ideally, samples should be sent to the lab within a day. If they are not sent within a day, they should be frozen until shipped. It is best to send samples early in the week so they don’t arrive at the lab on weekends and holidays, causing them to sit around longer than desired. Be sure to clearly label the sample and completely fill out the lab information sheet that accompanies the sample.

## **RECOMMENDED TESTS**

Most labs have a basic manure test package with the option to add other tests for an additional fee. Make sure the tests or test package you select includes at least the following analyses for nutrient management planning:

- Percent moisture or percent solids
- Total nitrogen
- Ammonium-nitrogen (NH<sub>4</sub>-N)
- Total phosphorus (P)
- Total potassium (K)

Other analyses that may be useful in some situations include pH, carbon-to-nitrogen (C:N) ratio, water-extractable P, calcium carbonate equivalent, secondary nutrients (Ca, Mg, and S), and micronutrients (Cl, Na, Cu, Mn, Zn,

and Fe). Usually it is not necessary to analyze manure for nutrients such as Ca, Mg, Zn, and boron. Most manure contains significant amounts of these nutrients and fields with a history of manure application are rarely deficient.

### **MANURE TEST RESULTS CAN BE REPORTED DIFFERENTLY**

Manure analysis results can be reported in several different ways; therefore, it is important to clearly understand how the manure test results are reported.

#### **Dry Matter or As Sampled?**

The first consideration is whether the results are reported on an as-sampled basis or on a dry-matter or dry-weight (dwt) basis. Most agricultural labs that do manure testing report the results on an as-sampled basis. If the results are reported on a dry-weight basis, the analyses will have to be converted back to as sampled to be practical for use in a nutrient management plan. See the “Common Manure Test Results Conversions” section for example calculations to convert analyses results from percent dry weight (% dwt) or ppm to “as-is” results (lb/ton or lb/1,000 gal).

#### **Reporting Units**

A second consideration in reporting manure test results is the reporting units used by the laboratory. When results are reported on an as-sampled basis, the most common units used are lb/ton for more solid samples and lb/1,000 gallons for liquid samples. However, carefully check the units on the manure test because other units are sometimes used. For example, some labs report liquid manure test results in lb/100 gallons. Pounds/acre-inch may be preferred by producers using irrigation systems. Also, particularly when results are reported on a dry-weight basis, percent (%) and parts per million (ppm) may be used. See the “Common Manure Test Results Conversions” section for example calculations to convert analyses results from percent dry-weight (% dwt) or ppm to “as-is” results (lb/ton or lb/1000 gal).

#### **Elemental or Oxide?**

A third consideration is that phosphorus and potassium results may be reported in the elemental form as P and K, or in the oxide form as  $P_2O_5$  and  $K_2O$ . Most agricultural labs that do manure testing report the results in the oxide form since this is how fertilizer recommendations are made. If the results are reported in the elemental form, they will have to be converted to the oxide form for use in nutrient management planning. See the “Common Manure Test Results Conversions” section for example calculations to convert analysis results from elemental to oxide.

#### **Solid or Liquid?**

Finally, there may be situations where the results are reported for a liquid manure (i.e., lb/1000 gal), but the manure is spread on a ton basis (i.e., tons/acre). The density of the manure can be used to convert the reported liquid analysis to a solid analysis. See the “Common Manure Test Results Conversions” section for example calculations to convert analysis results from liquid to solid or solid to liquid.

### **MANURE ANALYSIS RECORDS AND CREATING A BASELINE**

Manure nutrient analysis will vary from sample to sample on a farm, even with consistent management and careful sampling. Generally, a running average of manure analyses will better reflect manure nutrient content than any one sample result. Also, most of the sampling methods outlined here recommend sampling at the time the manure is being spread. This means that manure analysis results will not be available until after the manure is already spread. Therefore, nutrient management plans should be based on previous test results.

It is recommended to test manure annually for at least three years to establish a running average manure analysis that is used in the following year to develop the nutrient management plan. Table 1 illustrates how manure analysis records from a Pennsylvania dairy farm can be used to develop a useful manure analysis program. Only the N and solids analysis are shown here, but all test results would be analyzed similarly. In Table 1 the first three years are relatively consistent and the running average in the third column of this table would be used for planning the following year.

Once a baseline is established, less frequent manure testing may be acceptable. When a new manure analysis is obtained, it should be compared to the running average. If the new analysis is consistent with the average, it can be added to the running average. If there is an obvious trend—for example, manure analyses are slowly and consistently increasing or decreasing over time—the oldest value in the running average should probably be dropped when the new value is added.

If there is significant variation in the results, the following recommendations should be followed:

1. Extend the time frame for establishing a running average beyond the three years.
2. Try to identify the cause or causes of the variation.
3. Determine if management changes can be made to reduce the variation (e.g., better sampling, better agitation).
4. Determine if management changes can be made to react to the differences from year to year (e.g., increasing rates in a year when above-average rainfall dilutes the manure, adjusting rates based on changes in animal feeding).

If the new manure test result is very different from the running average, immediately try to determine the cause. Evaluate the sampling procedures, especially if there were no obvious management changes. Consider resampling the manure, if possible, to confirm or correct the inconsistent analysis. Look for management changes such as major changes in animal feeding, changes in dilution water in liquid manure (more or less rainfall, changes in washwater added, etc.), or changes in manure handling (manure scraped from barn floors more or less frequently, different bedding management, etc.). If the change was a one-time occurrence, do not add this test result to the running average.

In the example in Table 1, the value for Year 4 does not fit the trend. A review of the situation indicated that this was an abnormally dry year, thus there was less dilution from rainfall. Notice that the % solids were higher than previous levels, which is more evidence that the dry year was the cause. This value was not included in the running average. The farmer reduced his sidedress nitrogen (N) rate slightly that year to account for the higher N analysis and also lower yield potential because of the drought.

If a permanent management change was made, a new running average will need to be established based on more intensive sampling over a three-year period. For example, in Table 1 the N analysis changed dramatically for the sample in Year 8. In this case the farmer had made a major change in his feeding program, replacing corn with distillers grains. This would be consistent with the increased N in the manure. Since this was likely a permanent change, a new running average was started. Since the change in feeding management was known, some educated estimates about how this would affect the manure analysis were used to make adjustments in the nutrient management plan for Year 8 rather than using the existing running average.

Also, certain management adjustments may have to be made after manure application, such as applying more or less supplemental fertilizer to fields where the manure was spread. Plan to apply supplemental fertilizer after manure application has been completed and the actual manure nutrient application is known based on a current manure sample.

**Table 1. How manure analysis records from a Pennsylvania dairy farm can be used to develop a useful manure analysis program. Only the N and solids analysis are shown here, but all test results would be analyzed similarly.**

YEAR	MANURE TEST N (LB/1,000 GAL)	RUNNING AVERAGE N <sup>1</sup> (LB/1,000 GAL)	SOLIDS (PERCENT)
1	28	28	6.8
2	25	27	7.8
3	26	26	7.4
4	35 <sup>2</sup>	26	10.4
5	26	26	6.2
6	26	26	6.1
7	29	27	7.5
8	36 <sup>3</sup>	36	8.8
9	34	35	8.1
10	35	35	8.3

- Used to develop the nutrient management plan
- Value does not fit the trend. Example of one-time occurrence. See text for explanation.
- Value does not fit the trend. Example of permanent management change. See text for explanation.

## COMMON MANURE TEST RESULTS CONVERSIONS

**NOTE:** Phosphorus is used in these examples, but the calculations are the same for all nutrients.

### Converting manure analyses results from % dry weight (% dwt) or ppm to “as-is” results (lb/ton or lb/1,000 gal):

- lb/ton as sampled = (% solids/100) x (% analysis dwt/100<sup>1</sup>) x 2,000 lb/ton

or

- lb/1,000 gal = (% solids/100) x (% analysis dwt/1000) x (density<sup>2</sup> lb/gal x 1,000)

<sup>1</sup> For results in ppm, replace 100 with 1,000,000.

<sup>2</sup> To do this the density of the manure must be known. See the “Procedure for Estimating Manure Density” section.

#### Examples:

- Manure analysis: 10.5 percent solids, 1.4 percent P dwt  
(10.5% solids/100) x (1.4% P/100) x 2,000 = 2.9 lb P/ton
- Manure analysis: 10.5 percent solids; 14,000 ppm P dwt; manure density is 8.3 lb/gal (10.5% solids/100) x (14,000 ppm P/1,000,000) x (8.3 lb/gal x 1,000 gal) = 12.2 lb P/1,000 gal

### Converting Manure Analysis Results from Elemental to Oxide:

- Standard conversion factors: P x 2.3 = P<sub>2</sub>O<sub>5</sub>; K x 1.2 = K<sub>2</sub>O

#### Examples:

- Manure analysis: 2.9 lb P/ton  
2.9 lb P/ton x 2.3 = 6.7 lb P<sub>2</sub>O<sub>5</sub>/ton
- Manure analysis: 12.2 lb P/1,000 gal  
12.2 lb P/1,000 gal x 2.3 = 28.1 lb P<sub>2</sub>O<sub>5</sub>/1,000 gal

### Converting Manure Analysis Results from Liquid to Solid or Solid to Liquid:

To do this the density of the manure must be known. See the “Procedure for Estimating Manure Density” section.

- lb/ton = lb/1,000 gal ÷ (density lb/gal x 1,000) x 2,000 lb/ton

or

- lb/1,000gal = lb/ton x (density lb/gal x 1,000) ÷ 2,000

#### Examples:

- Manure analysis: 27.8 lb P<sub>2</sub>O<sub>5</sub>/1,000 gal;  
Manure density estimated at 8.3 lb/gal  
27.8 lb P<sub>2</sub>O<sub>5</sub>/1,000 gal ÷ (8.3 lb/gal x 1,000) x 2,000 = 6.7 lb P<sub>2</sub>O<sub>5</sub>/ton
- Manure analysis: 6.7 lb P<sub>2</sub>O<sub>5</sub>/ton;  
Manure density estimated at 8.3 lb/gal  
6.7 lb P<sub>2</sub>O<sub>5</sub>/ton x (8.3 lb/gal x 1,000) ÷ 2000 = 27.8 lb P<sub>2</sub>O<sub>5</sub>/1,000 gal

### **PROCEDURE FOR ESTIMATING MANURE DENSITY**

Manure density varies with moisture content primarily depending on the amount of bedding. Liquid manure density can vary from 8 to 9 lb/gal but will typically have a density around 8.3 to 8.5 lb/gal. Manure density can be easily estimated with a five-gallon bucket and a set of scales. To calculate a more accurate estimate of manure density, use the procedure below:

1. Weigh an empty five-gallon bucket. Record the weight in pounds.
2. Fill the five-gallon bucket with a typical sample of the manure and weigh the bucket and manure. Record the weight in pounds.
3. Subtract the weight of the empty bucket (Step 1) from the weight of the bucket with manure (Step 2). Record the weight of the manure in pounds.
4. Repeat Steps 2 and 3 at least five times and calculate an average weight. Record the average weight in pounds.
5. Divide the average weight by 5 to determine the density in pounds per gallon

*or*

6. Multiply the average weight by 1.5 to determine the density in pounds per cubic foot.

### **ADDITIONAL REFERENCES**

Manure Testing on Livestock and Environment Learning Center eXtension website:

[www.extension.org/pages/ Manure\\_Testing](http://www.extension.org/pages/Manure_Testing)

“Sampling Livestock Waste for Analysis,” in John Peters and Sherry Combs, *Recommended Methods of Manure Analysis*, [http://pubwiki.extension.org/mediawiki/files/a/a5/Unit\\_I\\_Sampling\\_Livestock\\_Waste\\_for\\_Analysis.pdf](http://pubwiki.extension.org/mediawiki/files/a/a5/Unit_I_Sampling_Livestock_Waste_for_Analysis.pdf).

Prepared by Jerry Martin, senior project associate, and Douglas Beegle, professor of agronomy.

Development and printing of this fact sheet were supported by the Pennsylvania State Conservation Commission Nutrient Management Program.

Much of the material in this fact sheet was adapted from a website authored by Douglas Beegle, Penn State, and John Peters, University of Wisconsin.

**extension.psu.edu**

Penn State College of Agricultural Sciences research and extension programs are funded in part by Pennsylvania counties, the Commonwealth of Pennsylvania, and the U.S. Department of Agriculture.

Where trade names appear, no discrimination is intended, and no endorsement by Penn State Extension is implied.

This publication is available in alternative media on request.

Penn State is committed to affirmative action, equal opportunity, and the diversity of its workforce.

Produced by Ag Communications and Marketing

© The Pennsylvania State University 2009

Code UC207 04/14pod